

Key Features

- Key features of iBeam smart**
- Highest available power of single emitter, single-mode diode lasers
 - Ultimate long-term power and beam pointing stability
 - Diffraction limited, circular TEM₀₀ beam
 - Active thermal control of laser diode for best stability and reliability
 - Small-size, all-in-one OEM package
 - High performance, low noise laser diode driver incorporating μ -processor and RS 232 control
 - Feedback-Induced Noise Eraser (FINE)
 - Optional digital modulation with up to 250 MHz; simultaneous digital & analog modulation
 - Optional fiber coupling with up to 90 % SM/PM fiber coupling efficiencies

iBeam smart-S	Units	375-S	395-S	405-S	420-S	445-S	473-S	488-S	515-S	640-S	660-S	675-S	685-S	785-S
Wavelengths	nm	375	395	405	420	445	473	488	515	640	660	675	685	785
Wavelength range	nm	± 3	± 3	± 4	± 5	± 5	± 3	+ 1/- 5	± 5	+ 5/- 3	± 3	± 5	± 5	± 5
Output power	mW	18	120	120	120	50	20	100	50	150	130	25	50	125

Applications

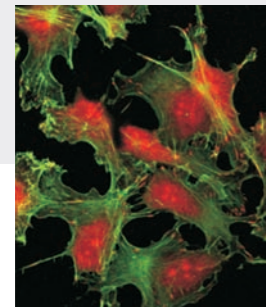

Confocal Microscopy

2D, 3D, 4D imaging of biological cells and tissues.

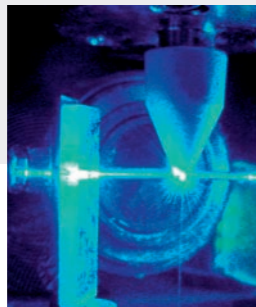

Flow Cytometry / HTS / HCS

Identification and separation of cells via laser fluorescence and scattering.

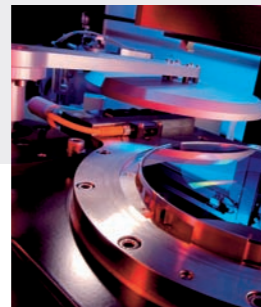

Disc Mastering

Exposure of CD, DVD or BD/HD glass masters.

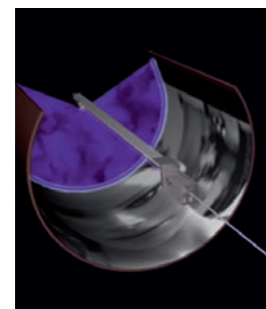

Reprographics/ CtP Printing

Exposure of silver halides or photopolymers.

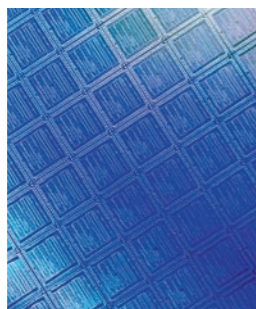

Microlithography

Direct exposure of photoresist in lithography masks.



Metrology

Optical thin film analysis by polarization and angle selective Fresnel reflections.

Mechanical Drawings

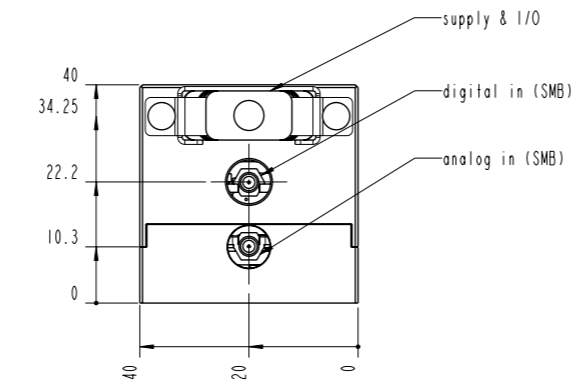
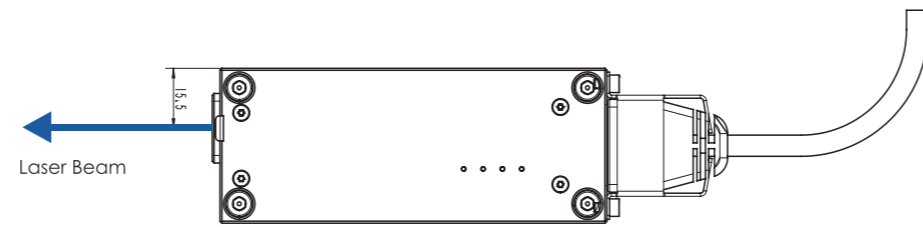
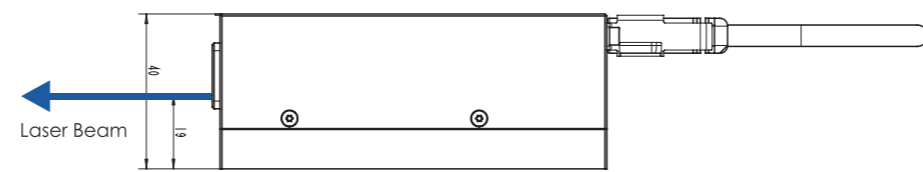
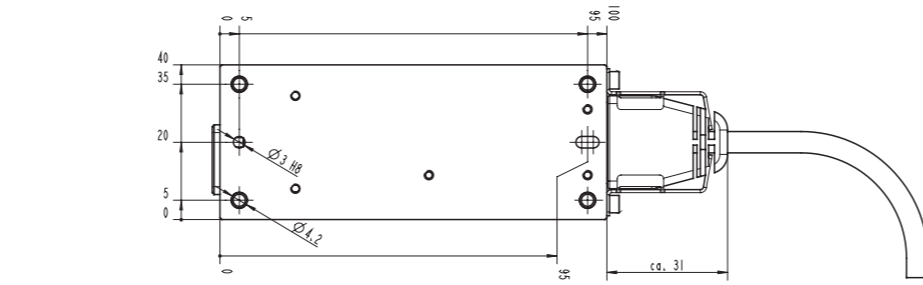

- BACK -

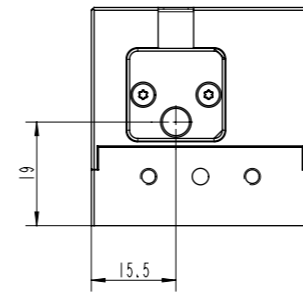

- FRONT -

All dimensions given in mm



TOPTICA Photonics AG
Lochhamer Schlag 19
D-82166 Graefelfing/Munich
Germany
Phone: +49 89 85837-0
Fax: +49 89 85837-200
info@toptica.com
www.toptica.com

TOPTICA Photonics, Inc.
1286 Blossom Drive
Victor/Rochester, NY 14564
U.S.A.
Phone: +1 585 657 6663
Fax: +1 877 277 9897
sales@toptica.com
www.toptica.com

Worldwide distribution offices: Australia & New Zealand · China · France · India · Israel · Japan · Korea · Singapore & Malaysia · Taiwan · Turkey · United Kingdom & Ireland

BR-042C-2011-01



iBeam smart

Ultra-Compact Diode Laser



- 375 nm
- 395 nm
- 405 nm
- 420 nm
- 445 nm
- 473 nm
- 488 nm
- 515 nm
- 640 nm
- 660 nm
- 675 nm
- 685 nm
- 785 nm

- Confocal Microscopy
- Digital Photo Finishing
- Disc Mastering
- Flow Cytometry
- Inspection
- Metrology
- Microlithography
- Microplate Readout
- Prepress, Computer-To-Plate
- Retina Scanning



Specifications

Smart Engineering — Pure Performance

iBeam smart-S	Units	375-S	395-S	405-S	420-S	445-S	473-S	488-S	515-S	640-S	660-S	675-S	685-S	785-S
Optical specifications														
Wavelengths*	nm	375	395	405	420	445	473	488	515	640	660	675	685	785
Wavelength range	nm	± 3	± 3	± 4	± 5	± 5	± 3	+ 1/- 5	± 5	+ 5/- 3	± 3	± 5	± 5	± 5
Output power	mW	18	120	120	120	50	20	100	50	150	130	25	50	125
Fiber coupled output power (guaranteed)	mW	12	70	70	70	35	14	60	30	100	90	16	30	90
Power stability (drift over 48 h @ room temperature ± 5°C)	%	< 0.5												
RMS noise (10 Hz – 10 MHz)	%	< 0.2												
Beam diameter (typ. @ 1/e ²)	mm	1.3	1.2	1.2	1.2	1.3	1.3	1.3	1.3	1.1	1.3	1.2	1.2	1.3
Beam shape (far field)		Circular												
Ellipticity	%	< 10												
Divergence (typ.)	mrad	< 0.6	< 0.6	< 0.6	< 0.6	< 0.6	< 0.7	< 0.7	< 0.7	< 1	< 1	< 1	< 1	< 1
M ²		< 1.2												
Pointing stability	µrad/K	< 5												
Static alignment** (x–y/angular)		± 0.2 mm, ± 0.5 mrad												
Polarization ratio (typ.)		> 100:1												
Polarization orientation		Linear, Vertical ± 3°												
Electronic specifications														
Digital modulation (option)														
Supported digital signal levels		TTL												
Max. digital modulation frequency	MHz	250												
Rise/Fall time (10% – 90%)	ns	< 1.5												
Digital modulation extinction ratio		> 1000:1												
Analog modulation														
Max. analog modulation frequency	MHz	1												
Analog modulation extinction ratio		10 ⁶												
Electronic shutter														
Rise/Fall time	µs	40/10												
Extinction ratio		∞ (complete off)												
General and environmental specifications														
Qualified		CE												
CDRH qualification		Class IIIb												
ESD protection		Level 4												
Digital communication interface		RS 232, ≤ 115.200 baud												
DC input requirements		12 V DC, 2A												
Power consumption	W	< 18 (typ. < 6)												
Max. heat dissipation (baseplate @ 50°C)	W	< 12												
Warm-up time	min	< 5												
Operating temperature range	°C	15 .. 40												
Storage temperature range	°C	- 10 .. 60												
Operating relative humidity (non-condensing)	%	< 90												
Dimensions (L x W x H)	mm ³	100 x 40 x 40												
Weight	g	< 250												
*Other wavelengths on request. **Static alignment tolerances are relative to reference holes in baseplate														

